

GERBANG LOGIKA DASAR

Gerbang Logika → blok dasar untuk membentuk rangkaian elektronika digital

- Sebuah gerbang logika mempunyai satu terminal output dan satu atau lebih terminal input
- Output-outputnya bisa bernilai HIGH (1) atau LOW (0) tergantung dari level-level digital pada terminal inputnya.
- Ada 7 gerbang logika dasar : AND, OR, NOT, NAND, NOR, Ex-OR, Ex-NOR

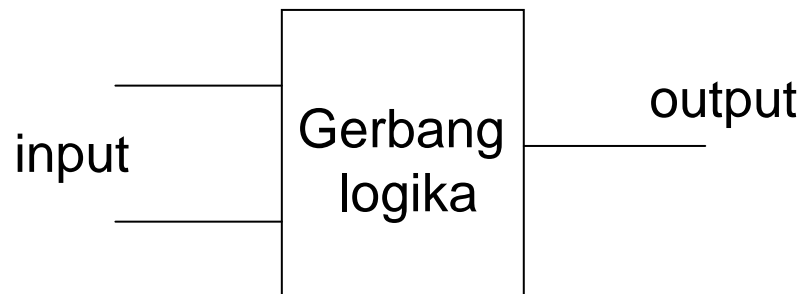

Gerbang AND

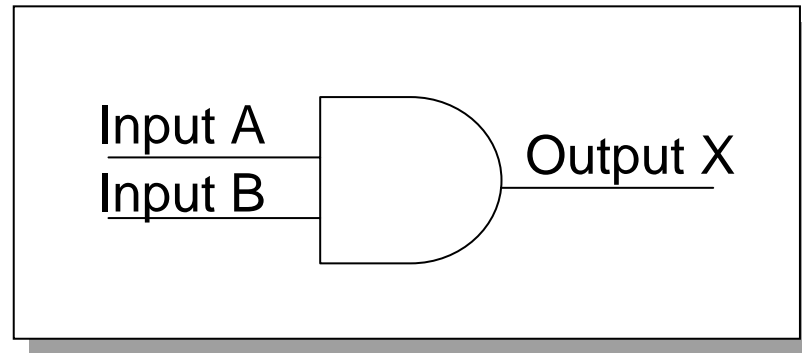

Simbol gerbang logika AND

Operasi AND :

- Jika Input A AND B keduanya **HIGH**, maka output X akan **HIGH**
- Jika Input A atau B salah satu atau keduanya **LOW** maka output X akan **LOW**

Tabel Kebenaran
gerbang AND – 2 input

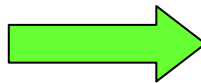

INPUT		Output
A	B	X
0	0	0
0	1	0
1	0	0
1	1	1

Cara kerja Gerbang AND :

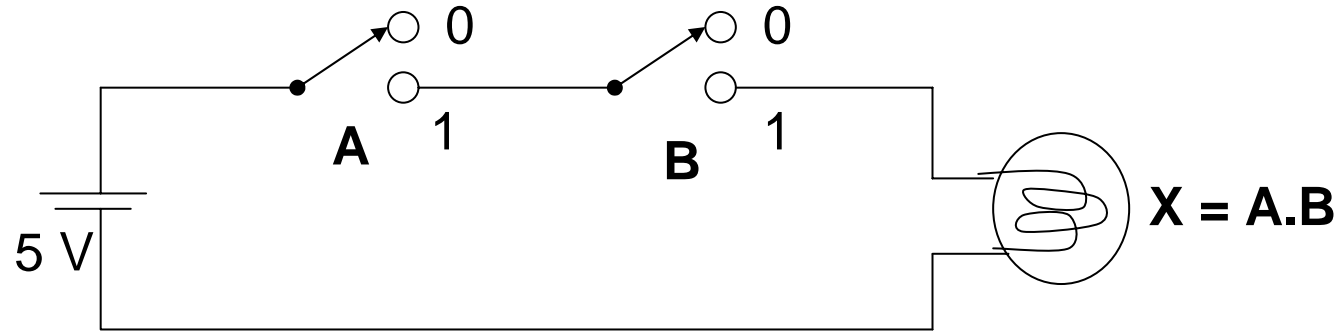

Analogi elektrikal gerbang AND

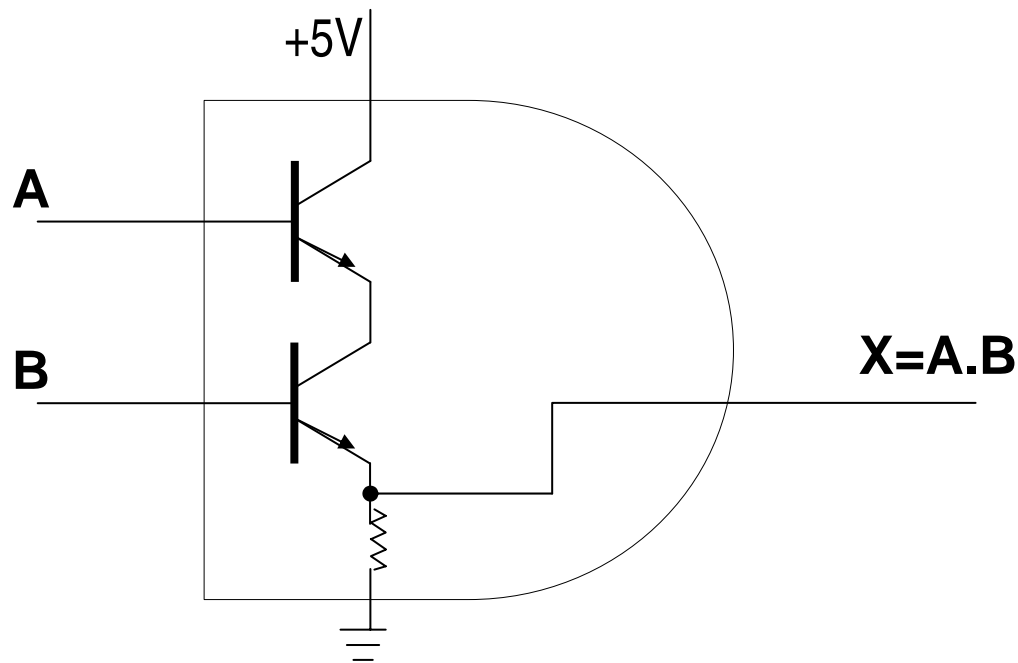

Gerbang AND dengan switch Transistor

Gerbang AND dengan banyak Input

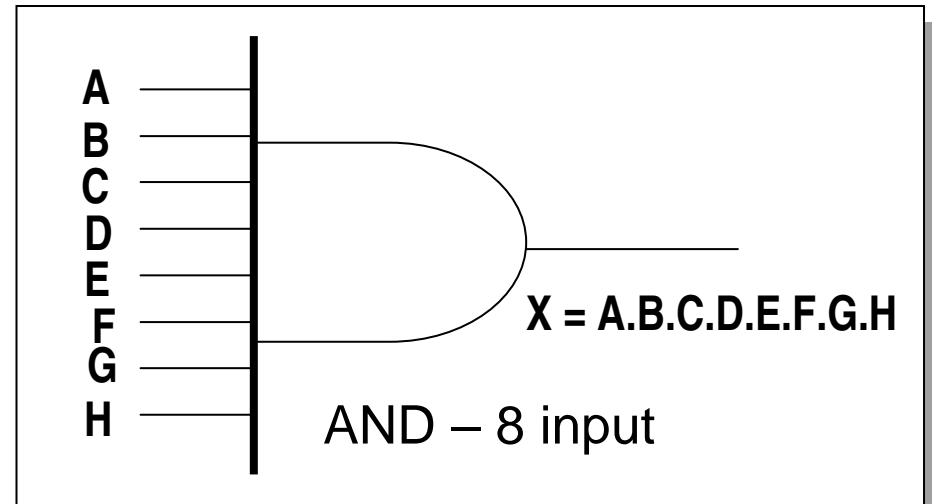
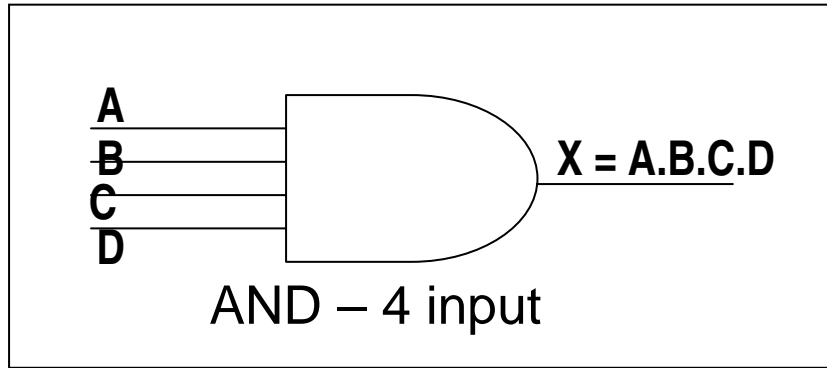

INPUT				Output
A	B	C	D	X
0	0	0	0	0
0	0	0	1	0
0	0	1	0	0
0	0	1	1	0
0	1	0	0	0
0	1	0	1	0
0	1	1	0	0
0	1	1	1	0
1	0	0	0	0
1	0	0	1	0
1	0	1	0	0
1	0	1	1	0
1	1	0	0	0
1	1	0	1	0
1	1	1	0	0
1	1	1	1	1

Tabel Kebenaran AND-4 input



Gerbang OR

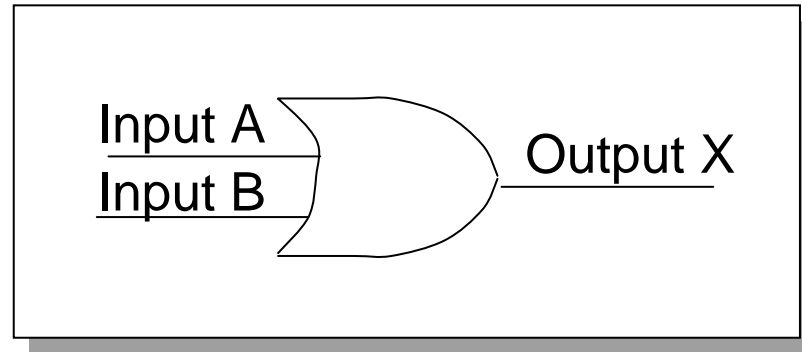

Simbol gerbang logika OR

Operasi OR :

- Jika Input A OR B atau keduanya **HIGH**, maka output X akan **HIGH**
- Jika Input A dan B keduanya **LOW** maka output X akan **LOW**

Tabel Kebenaran
gerbang OR – 2 input



INPUT		Output
A	B	X
0	0	0
0	1	1
1	0	1
1	1	1

Cara kerja Gerbang OR :

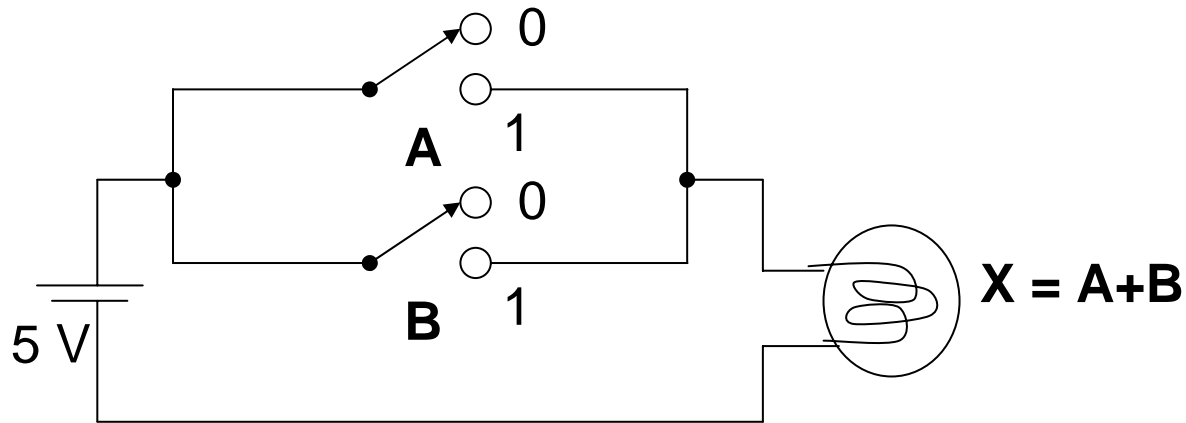

Analogi elektrik gerbang OR

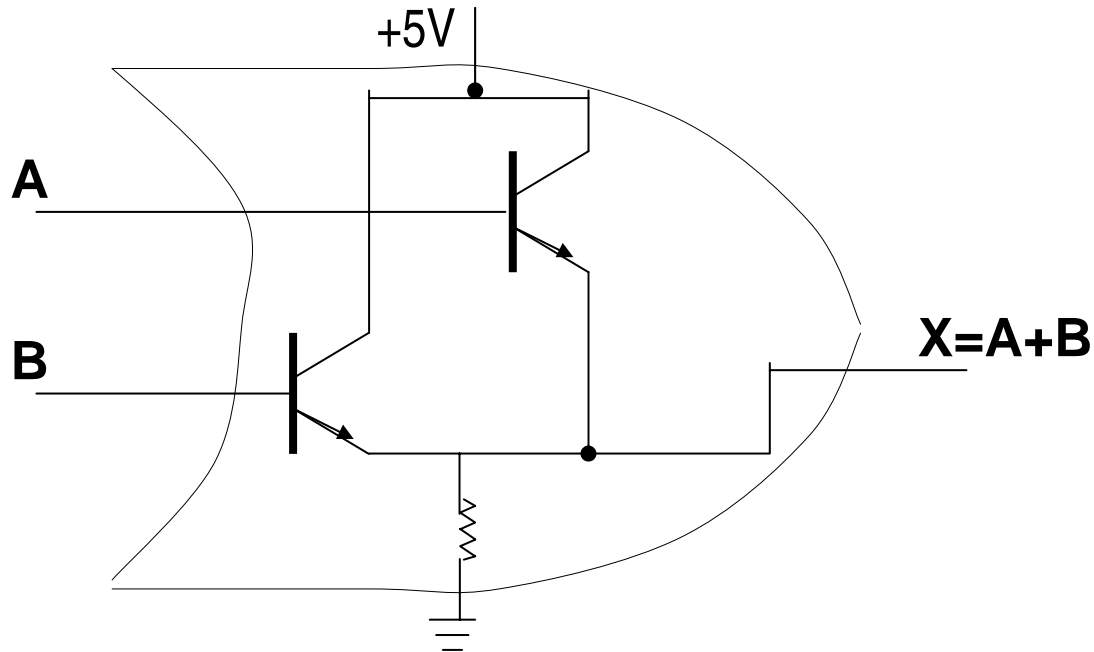

Gerbang OR dengan switch Transistor

Gerbang OR dengan banyak Input

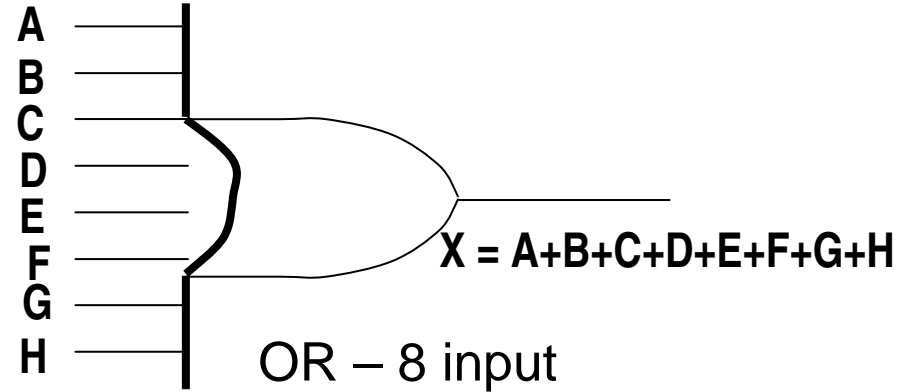
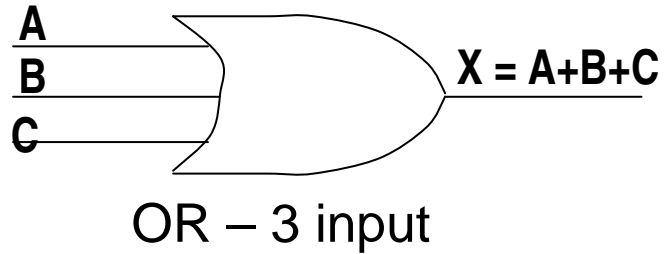

Tabel Kebenaran OR-3 input

INPUT			Output
A	B	C	X
0	0	0	0
0	0	1	1
0	1	0	1
0	1	1	1
1	0	0	1
1	0	1	1
1	1	0	1
1	1	1	1

Gerbang NOT / INVERTER

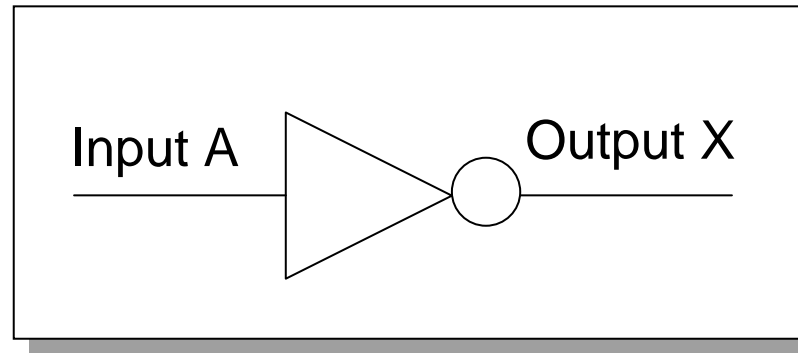

Simbol gerbang logika NOT

Operasi NOT :

- Jika Input A **HIGH**, maka output X akan **LOW**
- Jika Input A **LOW**, maka output X akan **HIGH**

$$X = \overline{A}$$

Tabel Kebenaran
gerbang NOT / INVERTER

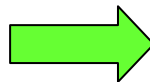

<i>INPUT</i> A	<i>Output</i> X
0	1
1	0

Gerbang NAND

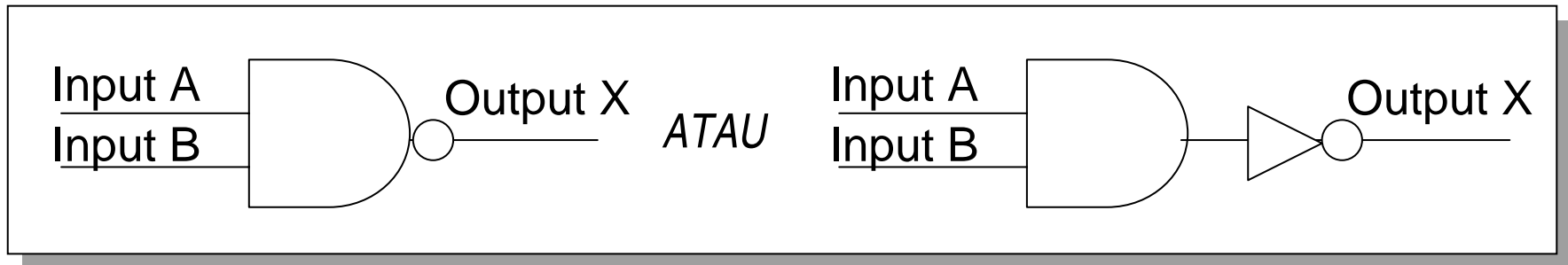

Simbol gerbang logika NAND

Operasi NAND :

- Merupakan Inversi (kebalikan) dari operasi AND
- Jika Input A AND B keduanya **HIGH**, maka output X akan **LOW**
- Jika Input A atau B atau keduanya **LOW**, maka output X akan **HIGH**

Tabel Kebenaran
gerbang NAND

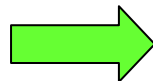

INPUT		Output
A	B	X
0	0	1
0	1	1
1	0	1
1	1	0

$$X = \overline{A \cdot B}$$

Gerbang NAND dengan banyak Input

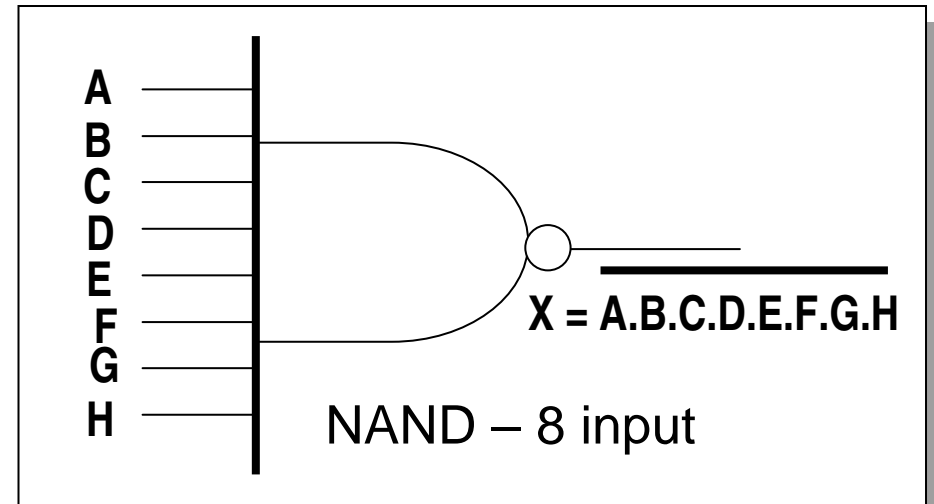
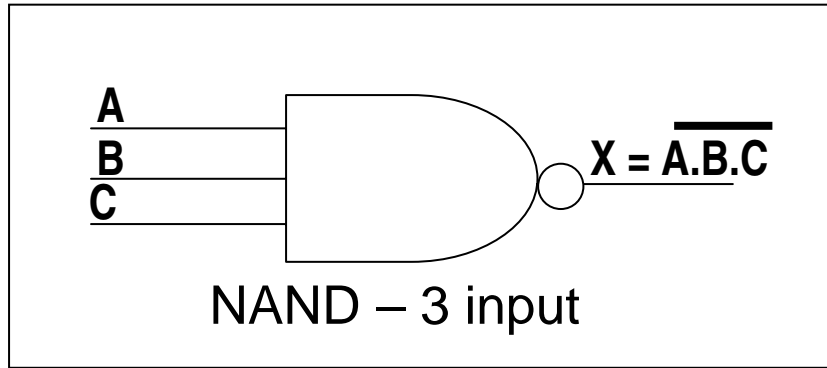

Tabel Kebenaran NAND-3 input

INPUT			Output
A	B	C	X
0	0	0	1
0	0	1	1
0	1	0	1
0	1	1	1
1	0	0	1
1	0	1	1
1	1	0	1
1	1	1	0

Gerbang NOR

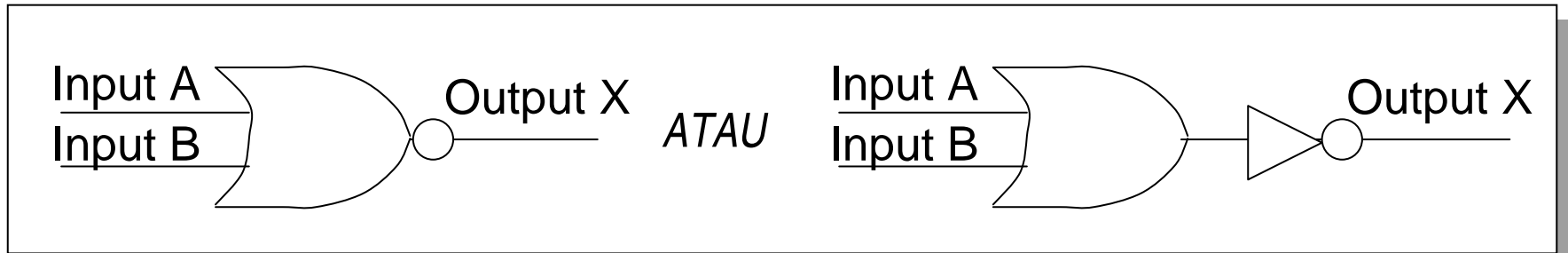

Simbol gerbang logika NOR

Operasi NOR :

- Merupakan Inversi (kebalikan) dari operasi OR
- Jika Input A dan B keduanya **LOW**, maka output X akan **HIGH**
- Jika Input A OR B salah satu atau keduanya **HIGH**, maka output X akan **LOW**

Tabel Kebenaran gerbang NOR

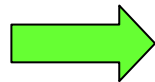

INPUT		Output
A	B	X
0	0	1
0	1	0
1	0	0
1	1	0

$$X = \overline{A+B}$$

Gerbang Ex-OR

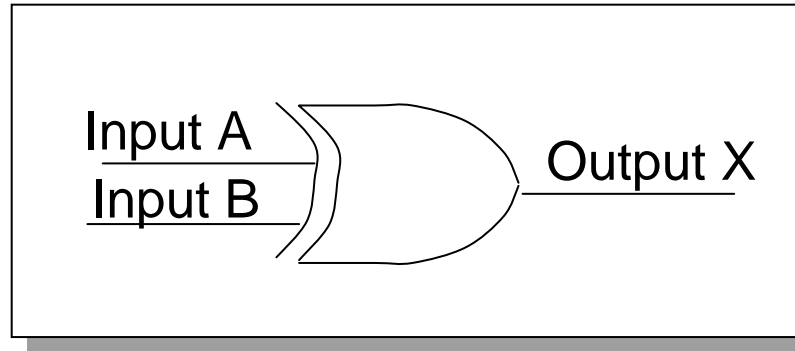

Simbol gerbang logika Ex-OR

Operasi Ex-OR :

- Ex-OR adalah kependekan dari Exclusive OR
- Jika salah satu dari kedua inputnya HIGH (bukan kedua-duanya), maka output X akan HIGH
- Jika kedua inputnya bernilai LOW semua atau HIGH semua, maka output X akan LOW

Tabel Kebenaran Gerbang Ex-OR

INPUT		OUTPUT
A	B	X
0	0	0
0	1	1
1	0	1
1	1	0

Persamaan Logika Ex-OR

$$X = A \oplus B$$

Berdasarkan Tabel Kebenaran di atas (yang bernilai output = 1), Ex-OR dapat disusun dari gerbang dasar : AND, OR dan NOT

Persamaan EX-OR (dari AND, OR dan NOT) :

$$X = \overline{A}B + A\overline{B}$$

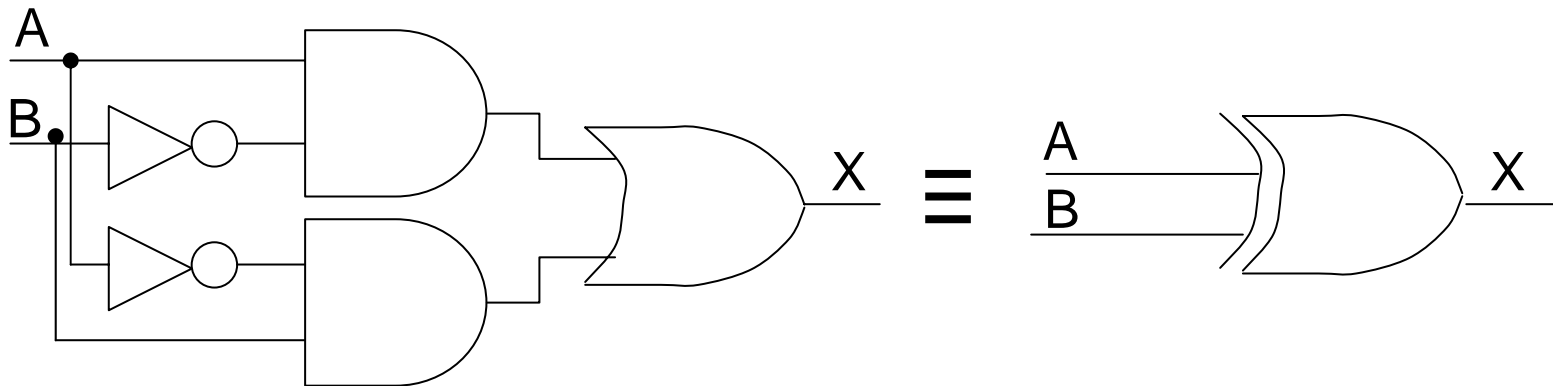

Gerbang Ex-OR dari AND, OR, NOT

Simbol logika Ex-OR

Gerbang Ex-NOR

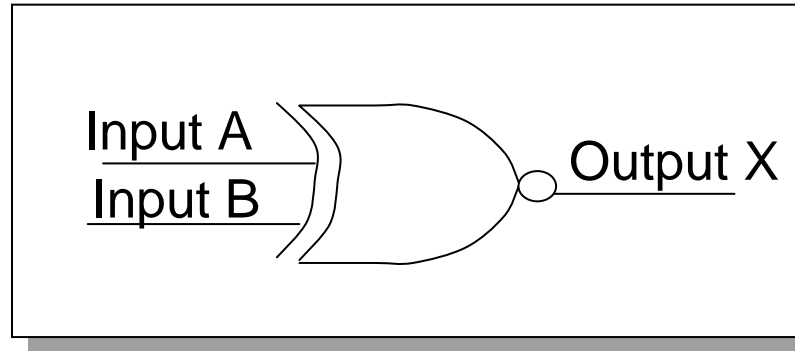

Simbol gerbang logika Ex-NOR

Operasi Ex-NOR :

- Ex-NOR merupakan kebalikan dari Ex-OR
- Jika salah satu dari kedua inputnya HIGH (bukan kedua-duanya), maka output X akan LOW
- Jika kedua inputnya bernilai LOW semua atau HIGH semua, maka output X akan HIGH

Tabel Kebenaran Gerbang Ex-NOR

INPUT		OUTPUT
A	B	X
0	0	1
0	1	0
1	0	0
1	1	1

Persamaan Logika Ex-NOR

$$X = \overline{A \oplus B}$$

Berdasarkan Tabel Kebenaran di atas (yang bernilai output = 1), Ex-NOR dapat disusun dari gerbang dasar : AND, OR dan NOT

Persamaan EX-NOR (dari AND, OR dan NOT) :

$$X = \overline{A} \overline{B} + AB$$

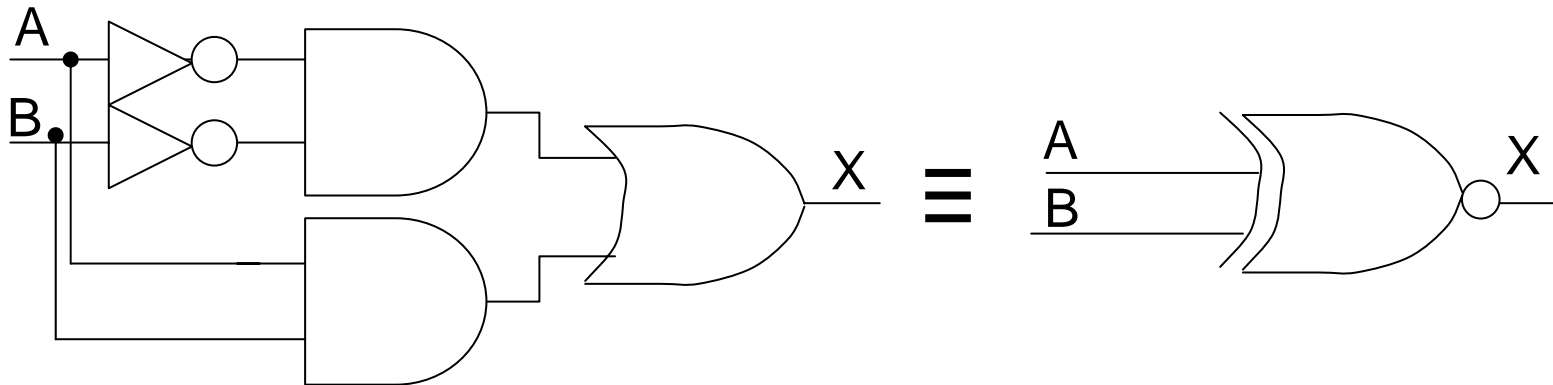

Gerbang Ex-NOR dari AND, OR, NOT

Simbol logika Ex-NOR

RINGKASAN JENIS GERBANG LOGIKA

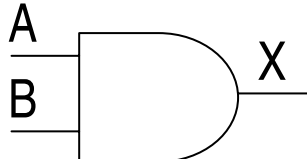
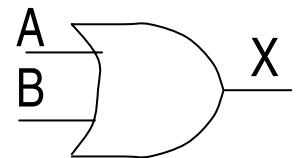
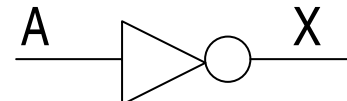
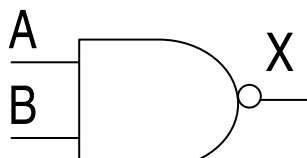
No	NAMA	TIPE IC	Simbol Logika	Persamaan	Tabel Kebenaran																		
1	AND	7408		$X=A.B$	<table border="1"> <thead> <tr> <th colspan="2">INPUT</th> <th>Output</th> </tr> <tr> <th>A</th> <th>B</th> <th>X</th> </tr> </thead> <tbody> <tr> <td>0</td> <td>0</td> <td>0</td> </tr> <tr> <td>0</td> <td>1</td> <td>0</td> </tr> <tr> <td>1</td> <td>0</td> <td>0</td> </tr> <tr> <td>1</td> <td>1</td> <td>1</td> </tr> </tbody> </table>	INPUT		Output	A	B	X	0	0	0	0	1	0	1	0	0	1	1	1
INPUT		Output																					
A	B	X																					
0	0	0																					
0	1	0																					
1	0	0																					
1	1	1																					
2	OR	7432		$X=A+B$	<table border="1"> <thead> <tr> <th colspan="2">INPUT</th> <th>Output</th> </tr> <tr> <th>A</th> <th>B</th> <th>X</th> </tr> </thead> <tbody> <tr> <td>0</td> <td>0</td> <td>0</td> </tr> <tr> <td>0</td> <td>1</td> <td>1</td> </tr> <tr> <td>1</td> <td>0</td> <td>1</td> </tr> <tr> <td>1</td> <td>1</td> <td>1</td> </tr> </tbody> </table>	INPUT		Output	A	B	X	0	0	0	0	1	1	1	0	1	1	1	1
INPUT		Output																					
A	B	X																					
0	0	0																					
0	1	1																					
1	0	1																					
1	1	1																					
3	NOT	7404		$X=\bar{A}$	<table border="1"> <thead> <tr> <th>INPUT</th> <th>Output</th> </tr> <tr> <th>A</th> <th>X</th> </tr> </thead> <tbody> <tr> <td>0</td> <td>1</td> </tr> <tr> <td>1</td> <td>0</td> </tr> </tbody> </table>	INPUT	Output	A	X	0	1	1	0										
INPUT	Output																						
A	X																						
0	1																						
1	0																						
4	NAND	7400		$X=\overline{A.B}$	<table border="1"> <thead> <tr> <th colspan="2">INPUT</th> <th>Output</th> </tr> <tr> <th>A</th> <th>B</th> <th>X</th> </tr> </thead> <tbody> <tr> <td>0</td> <td>0</td> <td>1</td> </tr> <tr> <td>0</td> <td>1</td> <td>1</td> </tr> <tr> <td>1</td> <td>0</td> <td>1</td> </tr> <tr> <td>1</td> <td>1</td> <td>0</td> </tr> </tbody> </table>	INPUT		Output	A	B	X	0	0	1	0	1	1	1	0	1	1	1	0
INPUT		Output																					
A	B	X																					
0	0	1																					
0	1	1																					
1	0	1																					
1	1	0																					

RINGKASAN JENIS GERBANG LOGIKA.....cont

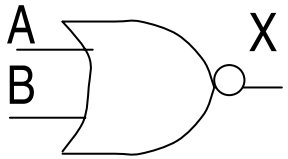
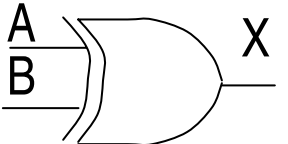
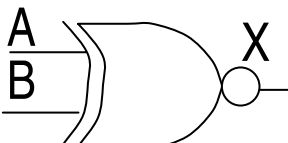
No	NAMA	TIPE IC	Simbol Logika	Persamaan	Tabel Kebenaran																		
5	NOR	7402		$X = \overline{A+B}$	<table border="1" style="margin: auto; border-collapse: collapse;"> <thead> <tr> <th colspan="2">INPUT</th> <th>Output</th> </tr> <tr> <th>A</th> <th>B</th> <th>X</th> </tr> </thead> <tbody> <tr><td>0</td><td>0</td><td>1</td></tr> <tr><td>0</td><td>1</td><td>0</td></tr> <tr><td>1</td><td>0</td><td>0</td></tr> <tr><td>1</td><td>1</td><td>0</td></tr> </tbody> </table>	INPUT		Output	A	B	X	0	0	1	0	1	0	1	0	0	1	1	0
INPUT		Output																					
A	B	X																					
0	0	1																					
0	1	0																					
1	0	0																					
1	1	0																					
6	Ex-OR	7486		$X = A \oplus B$	<table border="1" style="margin: auto; border-collapse: collapse;"> <thead> <tr> <th colspan="2">INPUT</th> <th>OUTPUT</th> </tr> <tr> <th>A</th> <th>B</th> <th>X</th> </tr> </thead> <tbody> <tr><td>0</td><td>0</td><td>0</td></tr> <tr><td>0</td><td>1</td><td>1</td></tr> <tr><td>1</td><td>0</td><td>1</td></tr> <tr><td>1</td><td>1</td><td>0</td></tr> </tbody> </table>	INPUT		OUTPUT	A	B	X	0	0	0	0	1	1	1	0	1	1	1	0
INPUT		OUTPUT																					
A	B	X																					
0	0	0																					
0	1	1																					
1	0	1																					
1	1	0																					
7	Ex-NOR			$X = \overline{A \oplus B}$	<table border="1" style="margin: auto; border-collapse: collapse;"> <thead> <tr> <th colspan="2">INPUT</th> <th>OUTPUT</th> </tr> <tr> <th>A</th> <th>B</th> <th>X</th> </tr> </thead> <tbody> <tr><td>0</td><td>0</td><td>1</td></tr> <tr><td>0</td><td>1</td><td>0</td></tr> <tr><td>1</td><td>0</td><td>0</td></tr> <tr><td>1</td><td>1</td><td>1</td></tr> </tbody> </table>	INPUT		OUTPUT	A	B	X	0	0	1	0	1	0	1	0	0	1	1	1
INPUT		OUTPUT																					
A	B	X																					
0	0	1																					
0	1	0																					
1	0	0																					
1	1	1																					

ANALISA PE-WAKTU-AN

Cara penganalisaan response output terhadap kombinasi input-inputnya pada periode waktu tertentu,

Cara penganalisaan yang lain adalah dengan Tabel Kebenaran

Peralatan yang digunakan disebut : *Timing Diagram* (Diagram pe-waktu-an).

Bentuk Timing Diagram :

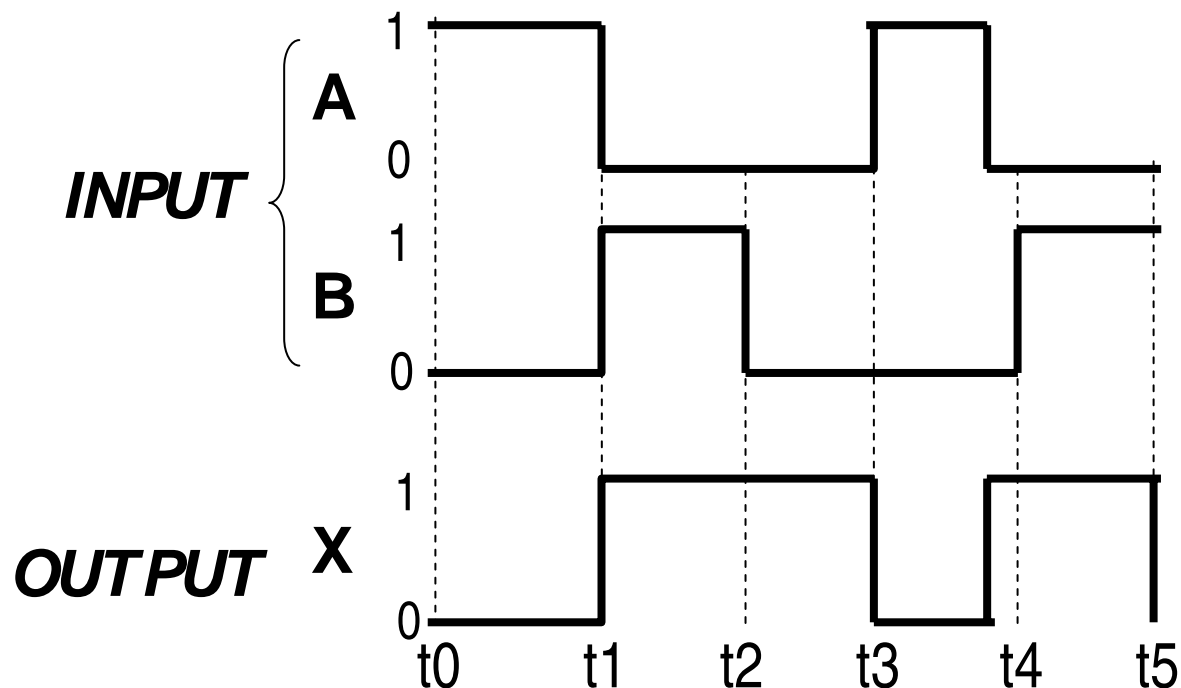

Contoh :

1. Buatlah timing diagram untuk mendapatkan output dari gerbang AND berikut ini :

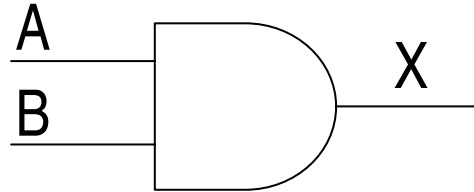

Jawab :

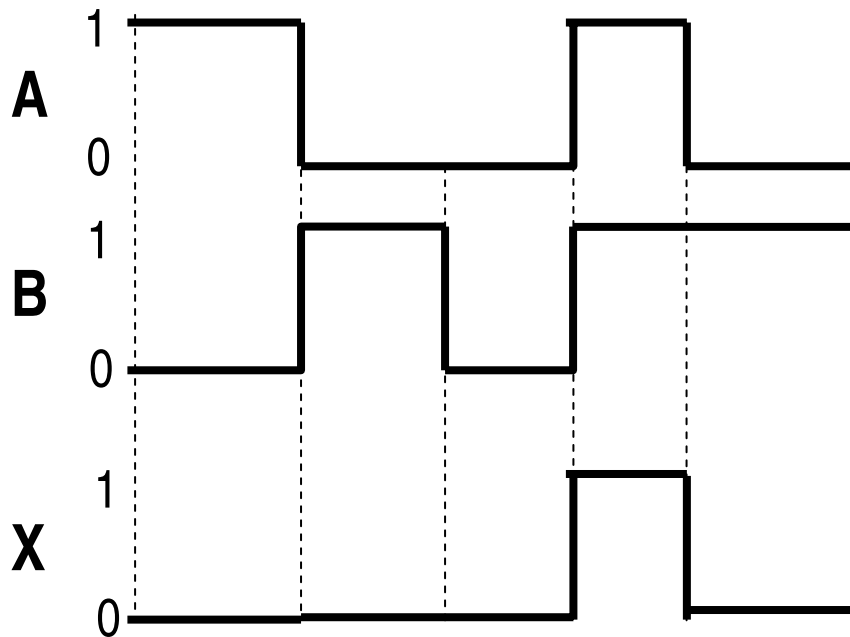

2. Buatlah timing diagram untuk mendapatkan output dari gerbang Ex-OR berikut ini :

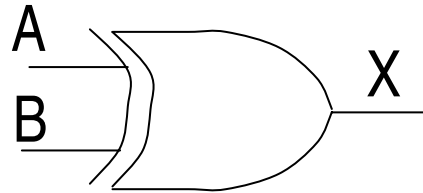

Jawab :

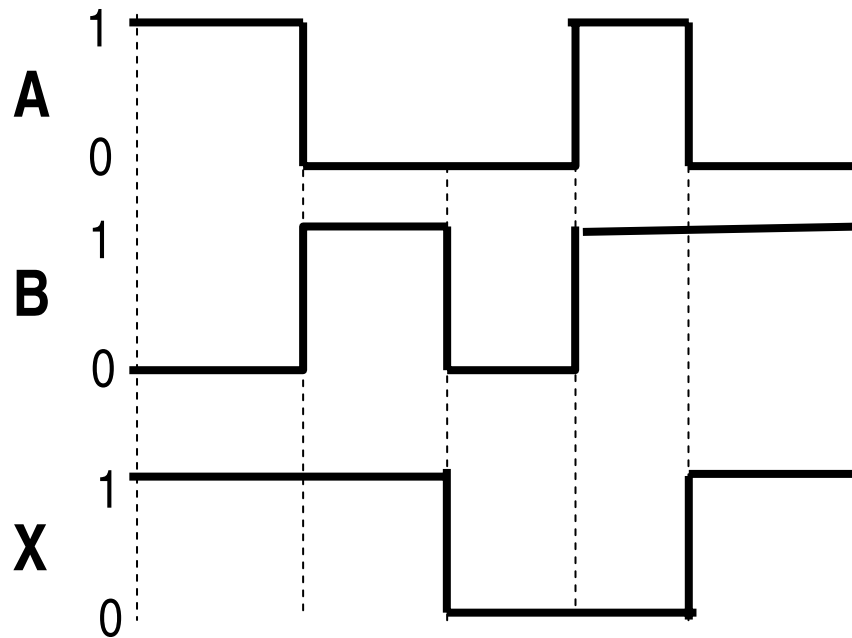

Soal Latihan :

1. Sebuah input data mempunyai urutan : 101110010. Gambarkan bentuk gelombang dari data input tersebut dalam representasi sinyal digital.
2. Sebutkan 3 jenis aplikasi yang menggunakan teknologi digital.
3. Buat Tabel Kebenaran untuk gerbang AND-3 input berikut ini :

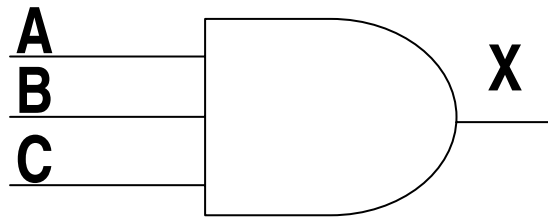

4. Buat Tabel Kebenaran untuk gerbang NOR-4 input berikut ini :

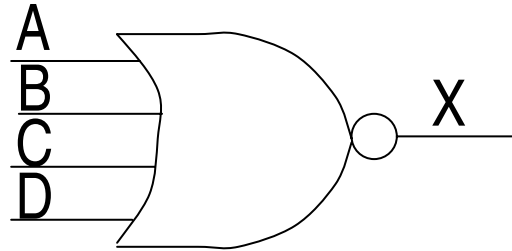

5. Buat Timing Diagram untuk output X dari gerbang OR-3 input berikut ini :

